

NOTES: (UNLESS OTHERWISE SPECIFIED)

1. CONFORMS IN ACCORDANCE WITH ALL TELECT WORKMANSHIP STANDARDS.

ITEM	PART NO.	DESCRIPTION	QTY
1	144051	MTG,BRKT:ISOLATOR,EXTENDER,2RU	2
2	144052	ISOLATOR:MTG BRKT,2RU	2
3	144057	BUSHING:ISOLATOR,ISOLATOR,1/4-20 X .158	4
4	119346	SCREW:12-24X1/2, PH, PHIL, TCS, TYPE F, GROUNDING, ZN PL,ROHS	8

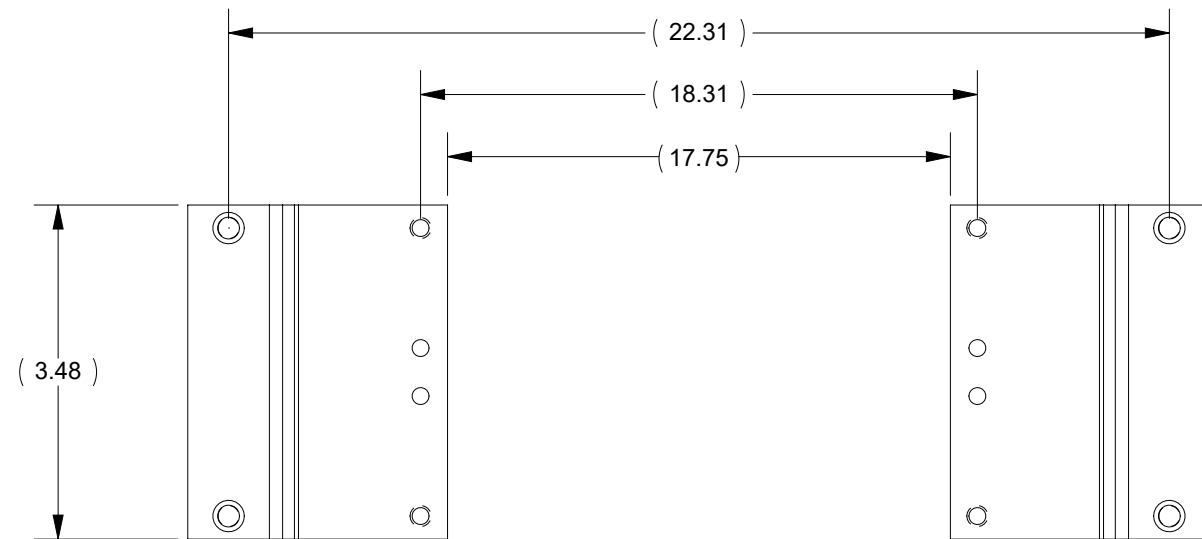
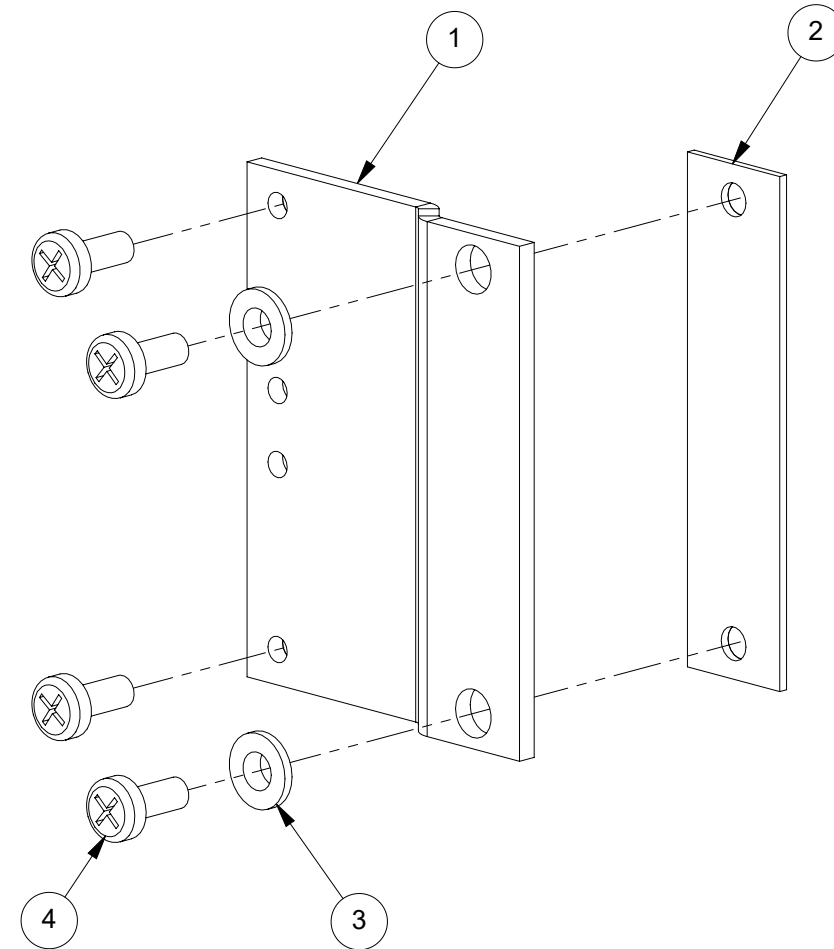
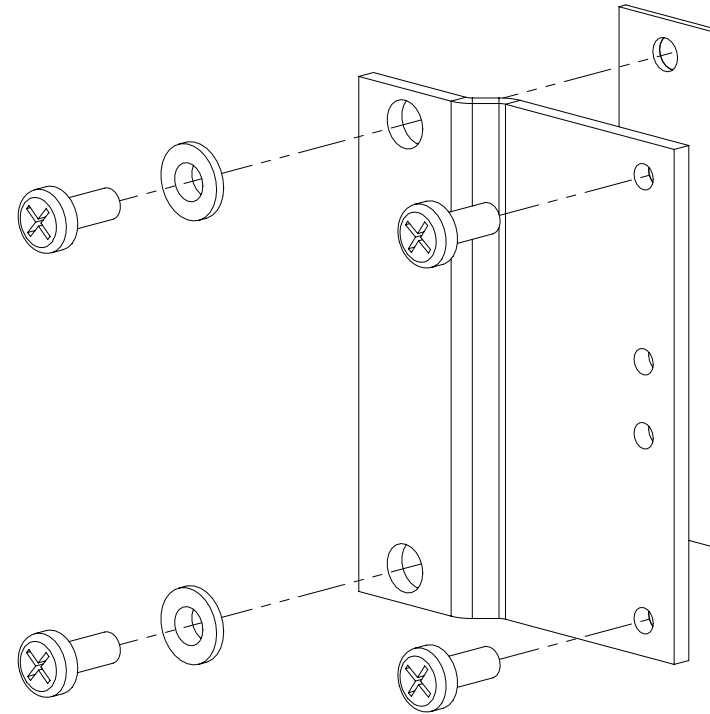

REV	ECO	DESCRIPTION	DATE	BY
A2	TEX4557	REDUCED BRKT LENGTH	9/13/2017	TMT
A1	---	ADDED INSIDE BRKT TO BRKT REF DIMENSION	10/02/2015	TMT
A1	TEX3982	CHG'D SCREW LENGTH FROM 3/8" TO 1/2"	06/07/13	TMT

drawing no	customer drawing	rev	units	designed by	date	tolerances (unless otherwise specified)	sheet	sheet size	scale	project	projection		
02117-021	ISOLATED PANEL ADAPTER W/HARDWARE AND ISO PAD 2 RU 23"-19" EIA	A2	inch	T. TURPIN	5/17/2013	.X ±.060 .XX ±.020 .XXX ±.010	1 of 1	B	NTS	R001			

designed by	date	tolerances (unless otherwise specified)	sheet	sheet size	scale	project	projection
T. TURPIN	5/17/2013	.X ±.060 .XX ±.020 .XXX ±.010	1 of 1	B	NTS	R001	
drawn by	date	hole size: ±.005 angularity: ±1°					
T. TURPIN	5/17/2013						

