

POWERED BY



WP-216

Work Platform for Cellular Pipe Frame

Dimensions

Height	990.6 mm 39.0 in
Length	304.8 mm 12.0 in
Weight	54.2 kg 119.5 lb
Width	3.0 m 10.0 ft

Environmental Specifications

Man Rating	250 lb vertical man load at 15 mph (BWS)
Wind Rating	120 mph (BWS) at 150 ft AGL 140 mph (3-second gust) at 150 ft AGL using Exposure D per FBC
Wind Rating Test Method	TIA/EIA-222

General Specifications

Product Type	Cellular pipe frame
Includes	Clamps Grating Hardware
Material Type	Hot dip galvanized steel
Mounting	Pipe, 114.3 mm (4-1/2 in) OD
Package Quantity	1

WP-216

POWERED BY



Outline Drawing

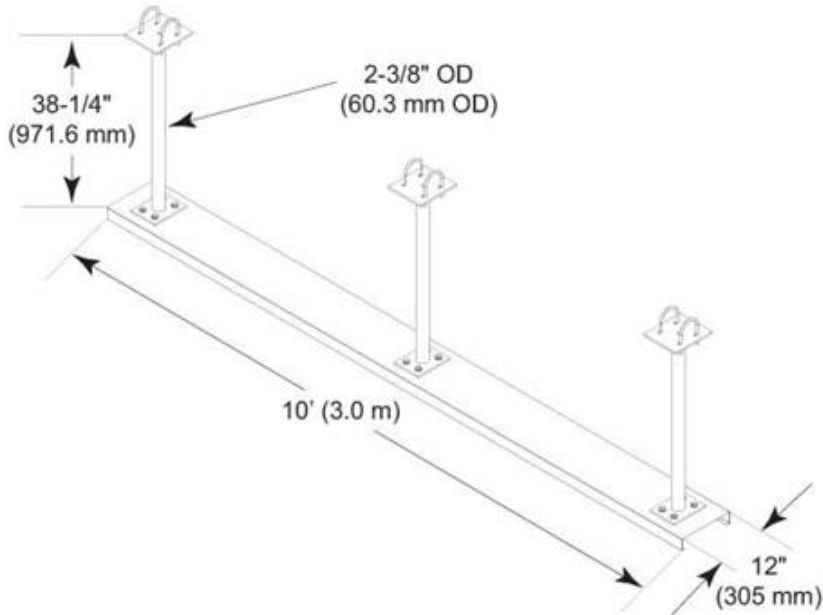

Regulatory Compliance/Certifications

Agency	Classification
ISO 9001:2008	Designed, manufactured and/or distributed under this quality management system

* Footnotes

Man Rating	BWS—Base Wind Speed
Wind Rating	BWS—Base Wind Speed; FBC—Florida Building Code