

Product Specifications

F4PNMV2-HC

Type N Male for 1/2 in FSJ4-50B cable

CHARACTERISTICS

General Specifications

Interface	N Male
Body Style	Straight
Brand	HELIAX®
Mounting Angle	Straight

Electrical Specifications

Connector Impedance	50 ohm
Operating Frequency Band	0 – 12000 MHz
Cable Impedance	50 ohm
3rd Order IMD	-120 dBm @ 910 MHz
3rd Order IMD Test Method	Two +43 dBm Carriers
RF Operating Voltage, maximum (vrms)	707.00 V
dc Test Voltage	2000 V
Outer Contact Resistance	0.30 mOhm
Inner Contact Resistance	2.00 mOhm
Insulation Resistance, minimum	5000 MOhm
Average Power	0.6 kW @ 900 MHz
Peak Power, maximum	10.00 kW
Insertion Loss, typical	0.05 dB
Shielding Effectiveness	-110 dB

Product Specifications

F4PNMV2-HC

Outline Drawing

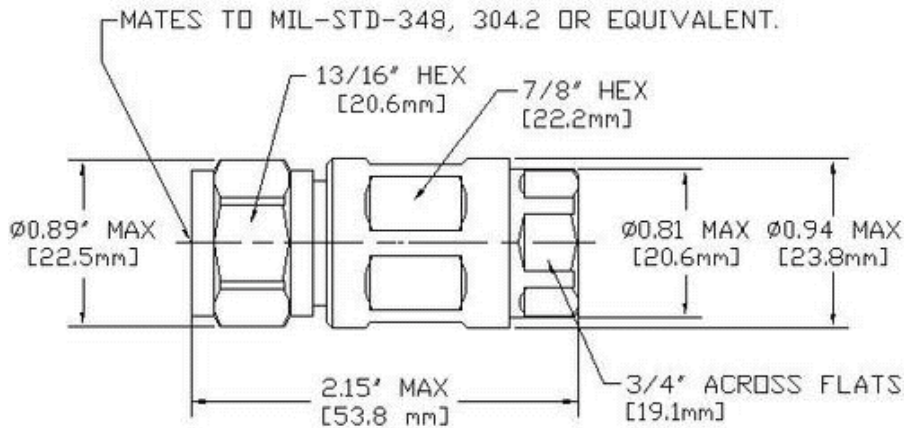

Mechanical Specifications

Outer Contact Attachment Method	Crush-flare
Inner Contact Attachment Method	Captivated
Outer Contact Plating	Trimetal
Inner Contact Plating	Gold
Attachment Durability	25 cycles
Interface Durability	500 cycles
Interface Durability Method	IEC 169-16:9.5
Connector Retention Tensile Force	890 N 200 lbf
Connector Retention Torque	5.42 N-m 48.00 in lb
Insertion Force	66.72 N 15.00 lbf
Insertion Force Method	MIL-C-39012C-3.12, 4.6.9
Pressurizable	No
Coupling Nut Proof Torque	4.52 N-m 40.00 in lb
Coupling Nut Retention Force	444.82 N 100.00 lbf
Coupling Nut Retention Force Method	MIL-C-39012C-3.25, 4.6.22

Dimensions

Nominal Size	1/2 in
Diameter, maximum	24.00 mm 0.95 in
Length	54.00 mm 2.13 in
Weight	90.72 g 0.20 lb

Environmental Specifications

Operating Temperature	-55 °C to +85 °C (-67 °F to +185 °F)
Storage Temperature	-55 °C to +85 °C (-67 °F to +185 °F)

F4PNM2-HC

Immersion Depth	1 m
Immersion Test Mating	Mated
Immersion Test Method	IEC 60529:2001, IP68
Water Jetting Test Mating	Mated
Water Jetting Test Method	IEC 60529:2001, IP66
Moisture Resistance Test Method	MIL-STD-202F, Method 106F
Mechanical Shock Test Method	MIL-STD-202F, Method 213B, Test Condition C
Thermal Shock Test Method	MIL-STD-202F, Method 107G, Test Condition A-1, Low Temperature -55 °C
Vibration Test Method	MIL-STD-202F, Method 204D, Test Condition B
Corrosion Test Method	MIL-STD-1344A, Method 1001.1, Test Condition A

Standard Conditions

Attenuation, Ambient Temperature	20 °C 68 °F
Average Power, Ambient Temperature	40 °C 104 °F

Return Loss

Frequency Band	VSWR	Return Loss (dB)
0–1000 MHz	1.03	36.00
1010–2000 MHz	1.04	35.00
2010–3000 MHz	1.08	28.00

Regulatory Compliance/Certifications

Agency	Classification
RoHS 2002/95/EC	Compliant by Exemption
China RoHS SJ/T 11364-2006	Above Maximum Concentration Value (MCV)



* Footnotes

Immersion Depth	Immersion at specified depth for 24 hours
Insertion Loss, typical	$0.05\sqrt{\text{freq (GHz)}}$ (not applicable for elliptical waveguide)

800.949.7079
order online today at www.talleycom.com